

OPEN AIR™

Air damper actuators

GDB..3..1
GLB..3..1

Rotary version, three-position control,
AC 24 V or AC 230 V



Electric motor-driven actuators for three-position control, 5 / 10 Nm nominal torque, AC 24 V or AC 230 V operating voltage, mechanically adjustable working range between 0...90°, pre-wired with connecting cables of 0.9 m. Type-specific variations with adjustable auxiliary switches for supplementary functions or with potentiometer for position indication.

Use

In ventilating and air conditioning plants to actuate air dampers

- with nominal torque of
 - 5 Nm for damper areas of approx. up to 0.8 m² and
 - 10 Nm for damper areas of approx. up to 1.5 m²
- ideal for modulating three-position controllers or ON/OFF controls (e.g., outside air dampers, flue gas dampers, etc.)

Type summary

Torque	Operating voltage					
	AC 24 V			AC 230 V		
	Standard version	with auxiliary switch	with positioner	Standard application	with auxiliary switch	with positioner
5 Nm	GDB131.1E	GDB136.1E	GDB132.1E	GDB331.1E	GDB336.1E	GDB332.1E
10 Nm	GLB131.1E	GLB136.1E	GLB132.1E	GLB331.1E	GLB336.1E	GLB332.1E

Ordering

You **cannot later install** auxiliary switches and positioners (potentiometer). For this reason, order the type that includes the desired options.

Delivery

Individual parts such as position indicator and other mounting materials for the actuator are delivered separately and require additional mounting.

Connecting cables

The actuator comes with 0.9 m long pre-wired connecting cables.

**Accessories,
spare parts**

- Rotary/linear set with lever
- Rotary/linear set with lever and mounting plate
- Spare parts are supplied on demand

ASK71.5
ASK71.6

**Equipment
combinations**

These actuators can be connected to all control devices with a three-position output supplying a switching voltage of AC 24 V or AC 230 V.

Functions

Basic functions

Rotational movement

The actuator's rotational movement (clockwise or counterclockwise) depends on the electrical control.

As soon as the operating voltage AC 24 V or AC 230 V is applied, the actuator starts to turn.

Three-position control

The connected damper can be operated as follows via the respective actuator control:

Example: clockwise direction

- damper opens (0°...90°)
- damper closes (90°...0°)

With no power applied, the damper remains in the respective position

Position indication

The position indicator inserted in the housing coupling bushing indicates the rotational angle position of the air damper.

Manual adjustment

When no voltage is supplied, you can disengage the gear train and manually adjust the actuator or the air damper by means of the red slider.

Mechanical limitation of
rotational angle

The rotational angle can be limited stepless between 0° and 90°.

**Type-specific
functions**

Adjustable auxiliary
switches

Auxiliary switches provide supplementary functions. The switching points for auxiliary switches A and B (one changeover switch each) can be set independently in increments of 5° within the 0°...90° rotational angle.

Refer to "Technical design", "Commissioning notes" and "Diagrams".

Electrical position
indication

The integrated potentiometer can be connected to voltage as a positioner; refer to "Technical data". The voltage applied is proportional to the actuator's rotational angle.

Technical design

Motor technology

A reversible synchronous motor enables accurate speed control. The magnetic coupling serves as a torque limitation on overload to protect both actuator and dampers.

Adjustable auxiliary switches (type-specific)

The illustration below shows the adjustable switching values for auxiliary switches A and B in relation to the rotational angle.

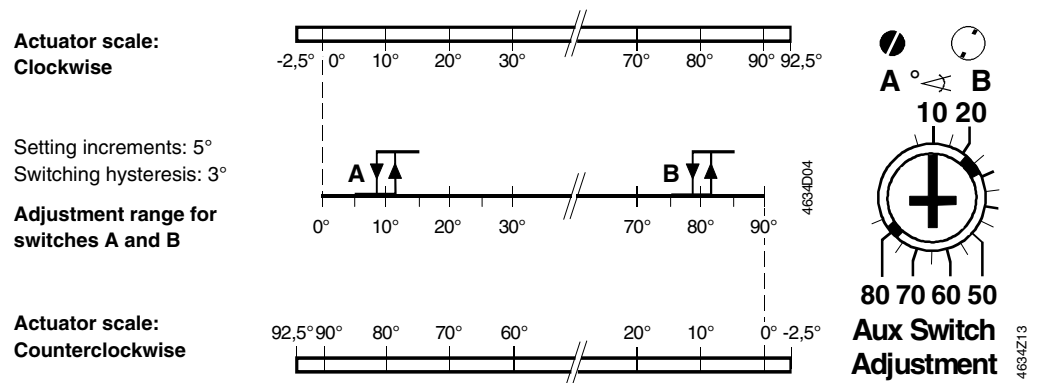

Note

The setting shafts for the auxiliary switches turn together with the actuator. The scales are valid only for the **zero position of the actuator** on **clockwise** movement.

Mechanical design

Basic components

Housing

A robust, light-weight plastic housing and a gear train plate made from steel guarantee an extended actuator life even under severe environmental conditions.

Gear train

Maintenance-free and noise-free gear train with stall and overload protection for the life of the actuator.

Slider for manual adjustment

The red slider on the side serves for manually releasing and adjusting the gear train.

Coupling bushing

The coupling bushing is made from hardened sintered steel to attach the actuator on the damper shaft for differing shaft diameters and cross sections (square, round).

Centering element GLB...1 (10 Nm)

This element is also made from hardened sintered steel and has the following purposes:

- ensuring a friction-locked connection between a damper shaft with a small diameter (8....10 mm) and the coupling bushing.
- reducing the vertical movement of the actuator by applying eccentric movement.

Mounting bracket

A metal strip with bolt serves to prevent the actuator from twisting.

Electrical connection

All actuators are equipped with pre-wired 0.9 m long connecting cables.

Type-specific elements

Auxiliary switch

For supplementary functions, the auxiliary switches A and B can be adjusted on the actuator front (top right).

Potentiometer for position indication

A potentiometer has been integrated as a positioner for the electrical position indication of the damper position.

Setting and operating elements

Refer to "Technical design" and "Commissioning notes" in this data sheet.

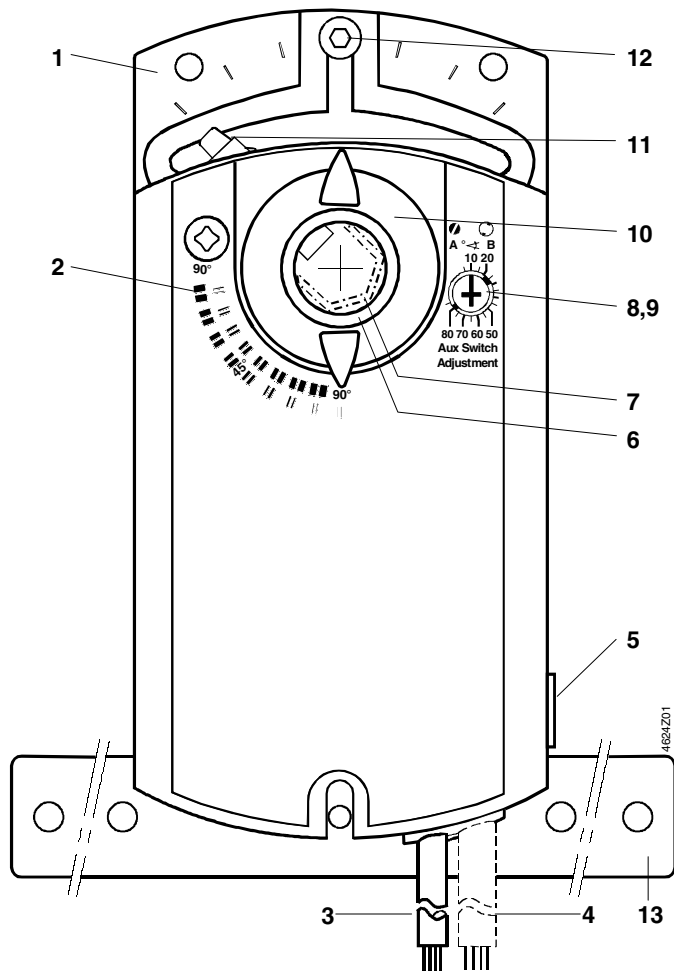

- 1 Base plate and housing
- 2 Rotational angle scales 0°...90° / 90°...0°
- 3 Connecting cable for power and positioning signal
- 4 Connecting cable for auxiliary switches or potentiometer
- 5 Slider to disengage the gear train
- 6 Coupling bushing
- 7 Centering element for GLB...1E for shaft diameters 8...10 mm)
- 8,9 Setting shafts for auxiliary switches A and B
- 10 Position indicator
- 11 Adjustment lever with shaft fastening screw
- 12 Adjusting screw for rotational angle limitation
- 13 Mounting bracket

Engineering notes



The basic system data for the control systems in use contain all engineering information; refer to this data prior to mounting, wiring, and commissioning the actuator and carefully read all safety information.

Intended use

Use these actuators in a system only for applications as described in the basic system documentation of the applied control systems. Additionally, include all actuator-specific features and conditions as described in the brief description on the title page of this data sheet (bold print) and in the chapters "Use", "Engineering notes", and "Technical data".



The sections flagged with a warning symbol as illustrated in the left margin contain safety-related requirements and restrictions; it is important that you adhere to them to prevent physical injuries or equipment damages.

⚠ AC 24 V supply

Operate the actuators only on **safety extra-low voltage (SELV)** or **protection by extra-low voltage (PELV)** as per HD 384.

⚠ AC 230 V supply

The actuators are double-insulated and do not provide a connection for the protective ground.

⚠ Auxiliary switches A, B

Apply **only mains voltage** or **only safety extra-low voltage** to the switching outputs of auxiliary switches A and B. Mixed operation is not permissible. However, operation using various phases is permissible.

 Potentiometer for positioner

Consider the potentiometer's electric data (max. load and sliding contact current).



Caution, maintenance

Do not open the actuator!

The unit is maintenance-free. Any repair work must be conducted by the manufacturer only.

Electric parallel connection of actuators

Electric connection in parallel of the GDB...1 actuators with GLB...1 is permissible only if the operating voltage is within the required tolerance. Remember to include voltage drops at the feed lines.

A relay must be used for electric connection in parallel when the actuators are operated with SQE...1, SQR...1, GBB...1 or GIB...1.

Note

Do not mechanically couple the actuators.

Required actuator type

Selection of the actuator depends on several torque factors. After obtaining the damper torque rating (Nm/m²) from the manufacturer and determining the damper area, calculate the total torque required to move the damper as follows:

$$\text{Total Torque} = \text{Torque Rating} \times \text{Damper Area}$$

Determine your type of actuator from the below table:

If $\frac{\text{Total torque [Nm]}}{\text{SF}^1}$	then use type
$\leq 5 \text{ Nm}$	GDB...1 (5 Nm)
$\leq 10 \text{ Nm}$	GLB...1 (10 Nm)
$\leq 20 \text{ Nm}$	GBB...1 (20 Nm)
$\leq 35 \text{ Nm}$	GIB...1 (35 Nm)

¹ Safety factor SF: When calculating the number of actuators, non-definable variables such as slight misalignment, damper age, etc. must be included as a safety factor. We recommend a safety factor of 0.80 (or 80% of the torque characteristic).

Sizing transformers for AC 24 V (SELV)

- Use safety insulating transformers with double insulation as per EN 60 742; the transformers must be made for 100% runtime.
- Observe all local safety rules and regulations pertaining to sizing and protection of transformers.
- Determine the transformer's power consumption by adding up the power consumption in VA for all actuators used.

Wiring and commissioning

Refer to "Commissioning notes" and "Diagrams" in this data sheet as well as to the HVAC job drawings.

Mounting notes

Mounting instructions

All information and steps to properly prepare and mount the actuator are listed in the Mounting Instruction guide supplied with the actuator. Both position indicator and mounting bracket are delivered separately.

Mounting position

Choose the actuator's mounting position so that you can easily access the cables as well as the setting shafts on the actuator front. Refer to "Dimensions".

Mounting bracket

When you mount the actuator directly on the damper shaft, use the mounting bracket. The pivot must have sufficient working depth in the base plate and sufficient play toward the shaft center, especially for smaller shaft diameters that cause greater eccentric movement.

Centering element GLB...1 (10 Nm)

To ensure a friction-locked connection at a shaft diameter of 8...10 mm, install the supplied centering element between the damper shaft and the coupling bushing as per the mounting instructions.

Damper shafts	Information on minimum length and diameter for the damper shaft is available in "Technical data".
Manual adjustment	Disconnect the voltage supply before manually adjusting the actuator via the red slider.
Mechanical limitation of rotational angle	Where required, you can set the rotational angle range by positioning the adjusting screw accordingly.
Using the linear mounting set	The mounting set as described in "Type summary" for changing the rotational movement to a linear stroke is mounted separately.

Commissioning notes

References	<p>For commissioning, the following reference documentation must exist:</p> <ul style="list-style-type: none"> • This data sheet: N4624 • Mounting instructions M4634 • Job diagram
Ambient conditions	Check to ensure that all permissible values as contained in the "Technical data" have been observed.
Mechanical check	<ul style="list-style-type: none"> • Check for proper mounting and to ensure that all mechanical settings correspond to the plant-specific requirements. Additionally, ensure that the dampers are shut tight when in the closed position. • Check the direction of rotation • Use the red slider (while no voltage is supplied) to manually adjust the dampers or the actuator. • Fasten the actuator securely to avoid twisting and blocking of the actuator.
Electrical check	<ul style="list-style-type: none"> • Check to ensure that the cables are connected in accordance with the plant wiring diagram (see "Diagrams"). • The operating voltage AC 24 V or AC 230 V (SELV/PELV) must be within the tolerance values. • Functional check: <ul style="list-style-type: none"> Control signal AC 24 V <ul style="list-style-type: none"> – between wires 1-6 : actuator turns clockwise. – between wires 1-7 : actuator turns counterclockwise. Control signal AC 230 V <ul style="list-style-type: none"> – between wires 4-6 : actuator turns clockwise. – between wires 4-7 : actuator turns counterclockwise. <p>The actuator remains in its current position if no control signal is applied.</p> • Measure the potentiometer's change of resistance while the actuator turns from 0...90°. • While the actuator reaches the respective switching positions the auxiliary switch contacts "A" and "B" must change.
Switches A and B: Factory setting	<p>The auxiliary switches have the following factory settings:</p> <p>Switch A: switching point at 5°</p> <p>Switch B: switching point at 85°</p> <p>The settings for A and B can be set to the desired values using the setting shafts; refer to "Technical design".</p>
Note	<ul style="list-style-type: none"> • In order to ensure an exact switching position for switches A and B, refer to "Adjustable auxiliary switches" under the "Technical design" heading. • The angle values are valid only for the "0°" actuator position (clockwise direction).

Technical data

⚠ Power supply AC24 V for GDB / GLB131.1E GDB / GLB132.1E GDB / GLB136.1E	Operating voltage	AC 24 V ± 20 %
	Safety extra-low voltage (SELV) or Protection by extra-low voltage (PELV) as per Requirements of external safety insulating transformer (100% ED)	HD 384 as per EN 60742
	Supply line fuse	max. 10 A
	Frequency	50/60 Hz
	Power supply (with control signal)	83 mA
	Power supply (with control signal)	2 VA/1 W
⚠ AC230 V supply for GDB / GLB331.1E GDB / GLB332.1E GDB / GLB336.1E	Operating voltage	AC 230 V ± 10 %
	Supply line fuse	max. 10 A
	Frequency	50/60 Hz
	Power supply (with control signal)	8.7 mA
	Power supply (with control signal)	2 VA/1 W
Mechanical data	Torque GDB..3..1E	
	Nominal torque	5 Nm
	Minimum holding torque (with/without operating voltage)	> 5 Nm
	Maximum torque	< 7 Nm
	Torque GLB..3..1E	
	Nominal torque	10 Nm
	Minimum holding torque (with/without operating voltage)	> 10 Nm
	Maximum torque	< 14 Nm
	Nominal rotational angle (with position indication)	90°
	Maximum rotational angle (mechanic limitation)	95° ± 2°
	Runtime for nominal rotational angle 90°, motor operation at 50/60 Hz	150 s / 125 s
	Rotational movement direction (defined by signal on wire 6 or 7)	clockwise / counterclockwise
Mechanical life	10 ⁵ cycles	
⚠ Inputs	Control signals AC 24 V	
	Wires 1-6	clockwise
	Wires 1-7	counterclockwise
	Control signals AC 230 V	
	Wires 4-6	clockwise
	Wires 4-7	counterclockwise
Outputs		
⚠ Auxiliary switch for GDB / GLB136.1E GDB / GLB336.1E	Number of changeover switches	2
	Life: 6 A resistive, 2 A inductive	10 ⁴ switchings
	5 A resistive, 1 A inductive without load	5 x 10 ⁴ switchings 10 ⁶ switchings
	Switching voltage	AC 24...230 V
	Nominal current resistive/inductive	6 A / 2 A
	Insulation resistance between auxiliary switches and housing	AC 4 kV
	Switching range of the auxiliary switches	5°...85°
	Setting increments	5°
	Switching hysteresis	3°
	Factory changeover settings	
	Switch A	5°
	Switch B	85°
	Positioner for GDB / GLB132.1E GDB / GLB332.1E	Potentiometer
Change of resistance (wires P1-P2)		0...1000 Ω
Load		< 1 W
Maximum sliding contact current		< 10 mA
Insulation resistance between potentiometer and housing		AC 500 V
Wire connections	Cable lengths	0.9 m
	Supply AC 24 V (wires 1, 6, 7) / AC 230 V (wires 4, 6, 7)	3 x 0.75 mm ²
	Auxiliary switches A and B (wires S1...S6)	6 x 0.75 mm ²
	Potentiometer (wires P1-P2)	3 x 0.75 mm ²
Housing protection	Degree of protection as per EN 60 529	IP40
Protection class	Insulation class	
	AC 24 V	III
	AC 230 V	II
	Auxiliary switch	II

Environmental conditions

Operation	IEC 721-3-3
Climatic conditions	Class 3K5
Mounting location	interior, weather-protected
Temperature	-30...55 °C
Humidity (non-condensing)	< 95% r.h.
Transport	IEC 721-3-2
Climatic conditions	Class 2K2
Temperature	-30...60 °C
Humidity (non-condensing)	< 95% r.h.
Mechanical conditions	Class 2M3

Standards

Product safety	EN 60 730-2-14
Automatic electrical controls for household and similar use (type 1)	
Electromagnetic compatibility	
Immunity	EN 50 082-2
Emissions	EN 50 081-1
CE Conformity	
Electromagnetic compatibility as per Low voltage directive	89/336/EEC 73/23/EEC

Dimensions

Actuator	
W x H x D	68 x 137 x 59.5 mm
see Dimensions	
Damper shaft	
Round	8...16 mm
Square	6...12 mm
Min. length	20 mm
Max. shaft hardness	< 300 HV
Centering element	
Used with GLB..3...1E for shaft diameter	8...10 mm

Weight

Without packaging	0.48 kg
-------------------	---------

Diagrams

Internal diagram

GDB/ GLB131.1E
GDB/ GLB132.1E
GDB/ GLB136.1E

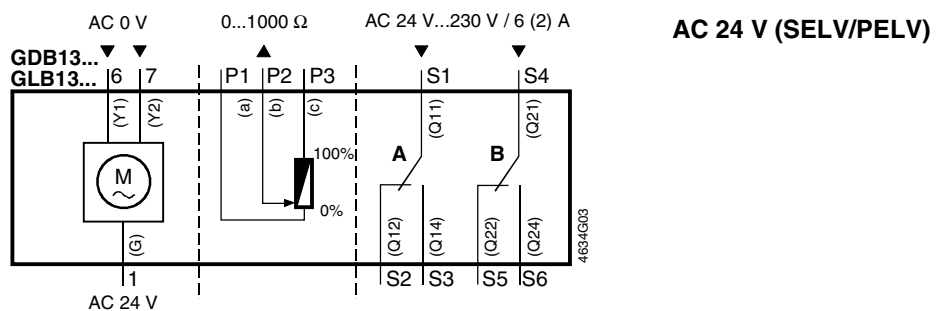

GDB/ GLB331.1E
GDB/ GLB332.1E
GDB/ GLB336.1E

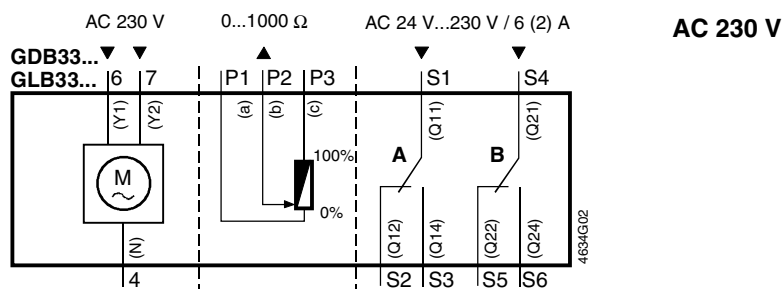

Cable	Wire labeling	Designation	Color	L&G terminal code
Actuator AC 24 V	1	System potential AC 24 V	red	G
	6	Control signal AC 24 V (0 V), clockwise	purple	Y1
	7	Control signal AC 24 V (0 V), counterclockwise	orange	Y2
Actuator AC 230 V	4	Neutral conductor	blue	N
	6	Control signal AC 230 V, clockwise	black	Y1
	7	Control signal AC 230 V, counterclockwise	white	Y2
Auxiliary switch	S1	Switch A Input	gray/red	Q11
	S2	Switch A Normally closed contact	gray/blue	Q12
	S3	Switch A Normally open contact	gray/pink	Q14
	S4	Switch B Input	black/red	Q21
	S5	Switch B Normally closed contact	black/blue	Q22
	S6	Switch B Normally open contact	black/pink	Q24
Positioner	P1	Potentiometer 0... 100 % (P1-P2)	white/red	a
	P2	Potentiometer pick-off	white/blue	b
	P3	Potentiometer 100... 0 % (P3-P2)	white/pink	c

Connection diagram

GDB/ GLB131.1E
GDB/ GLB132.1E
GDB/ GLB136.1E

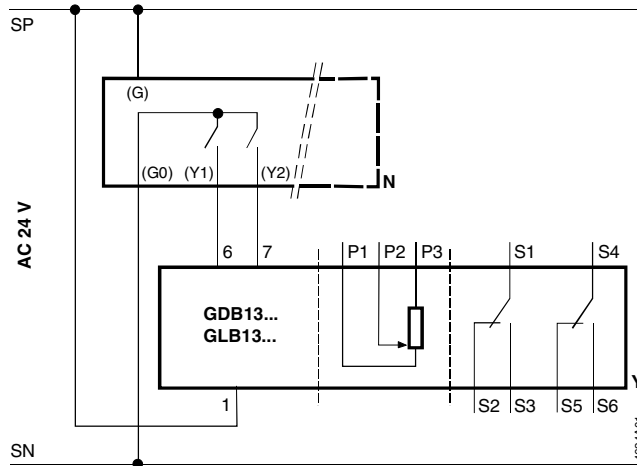

AC 24 V (SELV/PELV)

- N** Regulator or controller
- Y** Actuator, three-position:
GDB / GLB13..1, AC 24 V
- SP** System potential AC 24 V
- SN** System neutral

GDB/ GLB331.1E
GDB/ GLB332.1E
GDB/ GLB336.1E

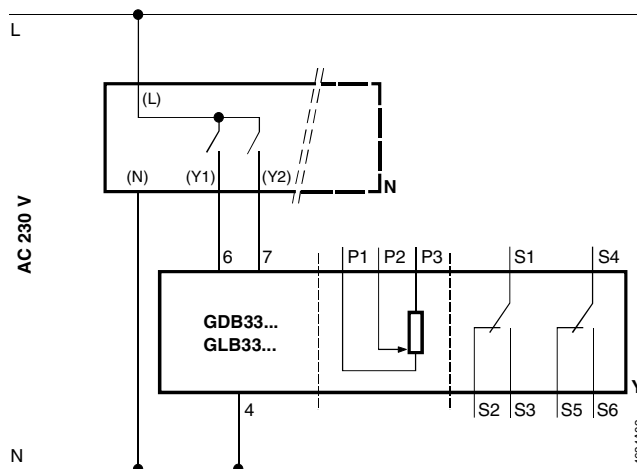

AC 230 V

- N** Regulator or controller
- Y** Actuator, three-position:
GDB / GLB33..1, AC 230 V
- L** Phase conductor AC 230 V
- N** Neutral conductor

Dimensions

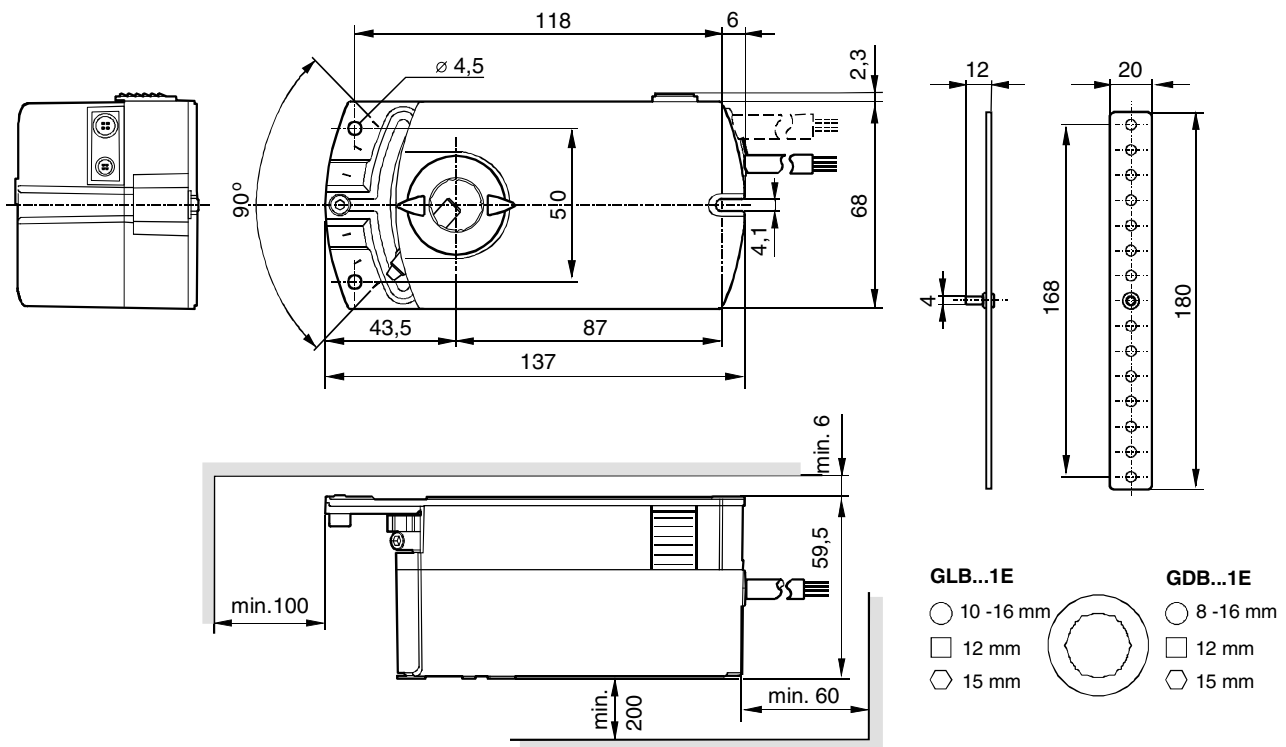

4634M01